

Doc. Number :

- Tentative Specification
- Preliminary Specification
- Approval Specification

**MODEL NO.: G121X1**  
**SUFFIX: L04**

**Customer:**

<b>APPROVED BY</b>	<b>SIGNATURE</b>
<b>Name / Title</b>	
Note	

---

Please return 1 copy for your confirmation with your signature and comments.

Approved By	Checked By	Prepared By
kj01.cheng (鄭光容/514-12216)	jason.mf.huang (黃名福/514-10919)	jason.mf.huang (黃名福/514-10919)
2015-08-21 17:25:52 CST	2015-05-15 08:17:08 CST	2015-05-14 12:29:52 CST

- CONTENTS -

REVISION HISTORY	-----	3
1. GENERAL DESCRIPTION	-----	4
1.1 OVERVIEW		
1.2 FEATURES		
1.3 APPLICATION		
1.4 GENERAL SPECIFICATIONS		
1.5 MECHANICAL SPECIFICATIONS		
2. ABSOLUTE MAXIMUM RATINGS	-----	6
2.1 ABSOLUTE RATINGS OF ENVIRONMENT		
2.2 ELECTRICAL ABSOLUTE RATINGS		
2.2.1 TFT LCD MODULE		
2.2.2 BACKLIGHT UNIT		
3. ELECTRICAL CHARACTERISTICS	-----	8
3.1 TFT LCD MODULE		
3.2 BACKLIGHT UNIT		
4. BLOCK DIAGRAM	-----	10
4.1 TFT LCD MODULE		
5. INPUT TERMINAL PIN ASSIGNMENT	-----	11
5.1 TFT LCD MODULE		
5.2 BACKLIGHT UNIT		
5.3 COLOR DATA INPUT ASSIGNMENT		
6. INTERFACE TIMING	-----	14
6.1 INPUT SIGNAL TIMING SPECIFICATIONS		
6.2 POWER ON/OFF SEQUENCE		
6.3 THE INPUT DATA FORMAT		
6.4 SCANNING DIRECTION		
7. OPTICAL CHARACTERISTICS	-----	18
7.1 TEST CONDITIONS		
7.2 OPTICAL SPECIFICATIONS		
8. RELIABILITY TEST CRITERIA	-----	22
9. PACKAGING	-----	23
9.1 PACKING SPECIFICATIONS		
9.2 PACKING METHOD		
10. DEFINITION OF LABELS	-----	25
11. PRECAUTIONS	-----	26
11.1 ASSEMBLY AND HANDLING PRECAUTIONS		
11.2 SAFETY PRECAUTIONS		
12. MECHANICAL CHARACTERISTICS	-----	27

**REVISION HISTORY**

Version	Date	Section	Description
2.0	Feb 23, 2010	All	G121X1-L04 Approval Spec. was first issued.
2.1	Oct 22, 2010	3.2	Add cautionary statement to Note(2) about life time vs. operating conditions.
2.2	Nov 20, 2014	2.1	Update ABSOLUTE RATINGS OF ENVIRONMENT Note (2) 90 %RH Max. (Ta < 40 °C). (3) Wet-bulb temperature should be 39 °C Max. removes (Ta > 40 °C).
		9.1	Update (3) Weight from 15Kg to 9.13Kg and Figure. 9-1 Packing method.
2.3	May 11, 2015	2.1	Update ABSOLUTE RATINGS OF ENVIRONMEN Note (5) The absolute maximum rating values of this product are not allowed to be exceeded at any times. The module should not be used over the absolute maximum rating value. It will cause permanently unrecoverable function fail in such an condition
		8	Update RELIABILITY TEST CRITERIA Note (5) Before cosmetic and function test, the product must have enough recovery time, at least 2 hours at room temperature. Note (6) Before cosmetic and function test, the product must have enough recovery time, at least 24 hours at room temperature.
		10.1	Update Serial ID information (a) Manufactured Date: Year: 1~9, for 2011~2019

## 1. GENERAL DESCRIPTION

### 1.1 OVERVIEW

The G121X1-L04 model is a 12.1" TFT-LCD IAV module with a white LED Backlight Unit and a 20-pin 1ch-LVDS interface. This module supports 1024 x 768 XGA mode and displays 262k/16.2M colors. The converter for the Backlight Unit is built in.

### 1.2 FEATURES

- Wide viewing angle
- High contrast ratio
- Fast response time
- XGA (1024 x 768 pixels) resolution
- Wide operating temperature
- DE (Data Enable) mode
- LVDS (Low Voltage Differential Signaling) interface
- Reversible scan direction
- RoHS Compliance

### 1.3 APPLICATION

- TFT LCD Monitor
- Industrial Application
- Amusement
- Vehicle

### 1.4 GENERAL SPECIFICATIONS

Item	Specification	Unit	Note
Diagonal Size	12.1	inch	(1)
Active Area	245.76(H) x 184.32(V)	mm	
Bezel Opening Area	249.0 x 187.5	mm	
Driver Element	a-si TFT active matrix	-	-
Pixel Number	1024 x R.G.B. x 768	pixel	-
Pixel Pitch	0.240(H) x 0.240(V)	mm	-
Pixel Arrangement	RGB vertical stripe	-	-
Display Colors	262k/16.2M	color	-
Transmissive Mode	Normally white	-	-
Surface Treatment	Hard coating (3H), AG	-	-
Module Power Consumption	6.6 (Black pattern)	W	Typ.

1.5 MECHANICAL SPECIFICATIONS

Item		Min.	Typ.	Max.	Unit	Note
Module Size	Horizontal (H)	260.2	260.5	260.8	mm	(1)
	Vertical (V)	239.7	204	204.3	mm	
	Depth (D)	6.7	7.2	7.7	mm	
Weight			435	465	g	-
I/F connector mounting position		The mounting inclination of the connector makes the screen center within $\pm 0.5\text{mm}$ as the horizontal.			-	(2)

Note (1) Please refer to the attached drawings for more information of front and back outline dimensions.

(2) Connector mounting position

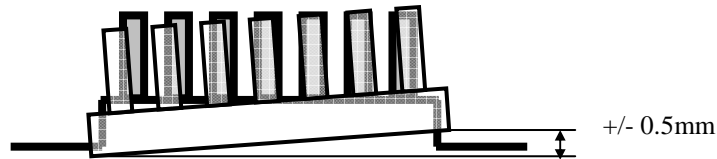

2. ABSOLUTE MAXIMUM RATINGS

2.1 ABSOLUTE RATINGS OF ENVIRONMENT

Item	Symbol	Value		Unit	Note
		Min.	Max.		
Operating Ambient Temperature	T <sub>OP</sub>	-30	+70	°C	
Storage Temperature	T <sub>ST</sub>	-40	+80	°C	

Note (1) Temperature and relative humidity range is shown in the figure below.

- (2) 90 %RH Max. (Ta < 40 °C).
- (3) Wet-bulb temperature should be 39 °C Max.
- (4) No condensation.
- (5) The absolute maximum rating values of this product are not allowed to be exceeded at any times.  
The module should not be used over the absolute maximum rating value. It will cause permanently unrecoverable function fail in such an condition

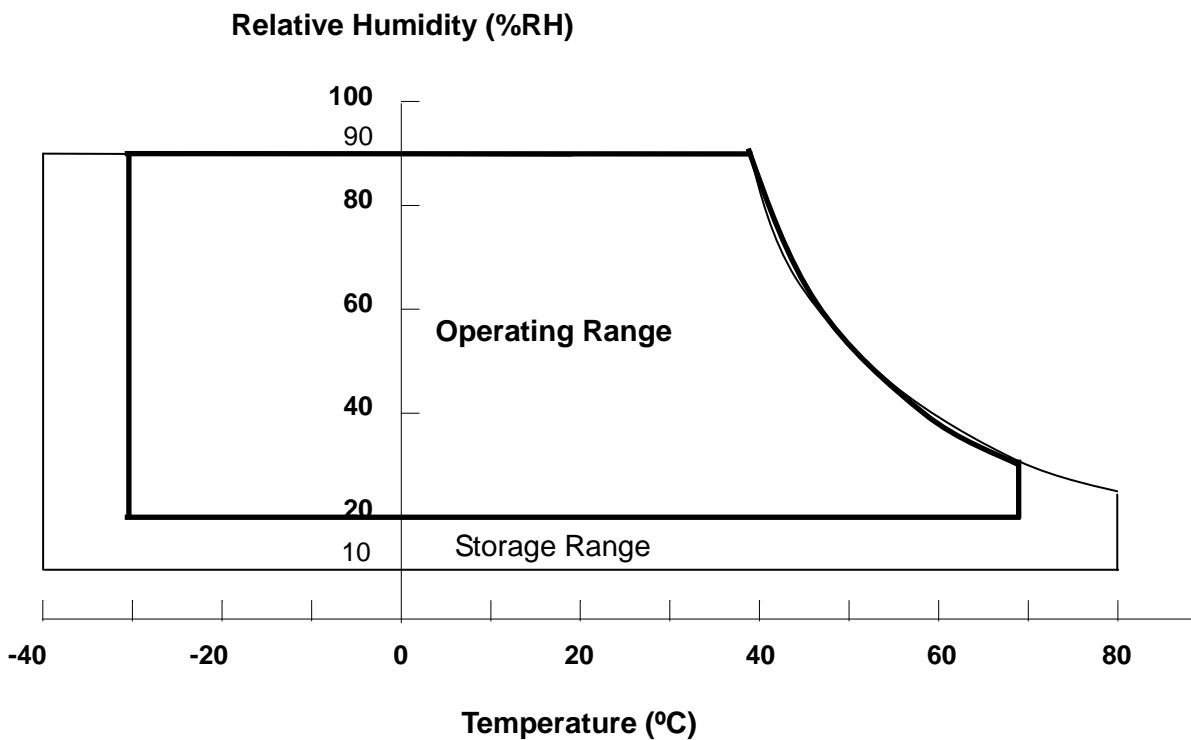

## 2.2 ELECTRICAL ABSOLUTE RATINGS

### 2.2.1 TFT LCD MODULE

Item	Symbol	Value		Unit	Note
		Min.	Max.		
Power Supply Voltage	VCC	-0.3	7	V	(1)

### 2.2.2 BACKLIGHT UNIT

Item	Symbol	Value		Unit	Note
		Min.	Max.		
Converter Voltage	$V_i$	-0.3	18	V	(1), (2)
Enable Voltage	EN	---	5.5	V	
Backlight Adjust	ADJ	---	5.5	V	

Note (1) Permanent damage to the device may occur if maximum values are exceeded. Function operation should be restricted to the conditions described under Normal Operating Conditions.

Note (2) Specified values are for lamp (Refer to 3.2 for further information).

3. ELECTRICAL CHARACTERISTICS

3.1 TFT LCD MODULE

Ta = 25 ± 2 °C

Parameter	Symbol	Value			Unit	Note	
		Min.	Typ.	Max.			
Power Supply Voltage	V <sub>CC</sub>	3.0	3.3	3.6	V	(1) at V <sub>CC</sub> =3.3V	
		4.75	5.0	5.25	V	(1) at V <sub>CC</sub> =5.0V	
Rush Current	I <sub>RUSH</sub>	-	-	4	A	(2)	
Power Supply Current	White	-	-	410	490	mA	(3)a, at V <sub>CC</sub> =3.3V
			-	320	395	mA	(3)a, at V <sub>CC</sub> =5.0V
	Black		-	540	650	mA	(3)b, at V <sub>CC</sub> =3.3V
			-	400	480	mA	(3)b, at V <sub>CC</sub> =5.0V
Power Consumption	P <sub>L</sub>	-	2.0	-	W		
LVDS differential input voltage	VID	100	-	600	mV	-	
LVDS common input voltage	V <sub>ICM</sub>	0.7	-	1.6	V	-	

Note (1) The assembly should be always operated within above ranges.

Note (2) Measurement Conditions:

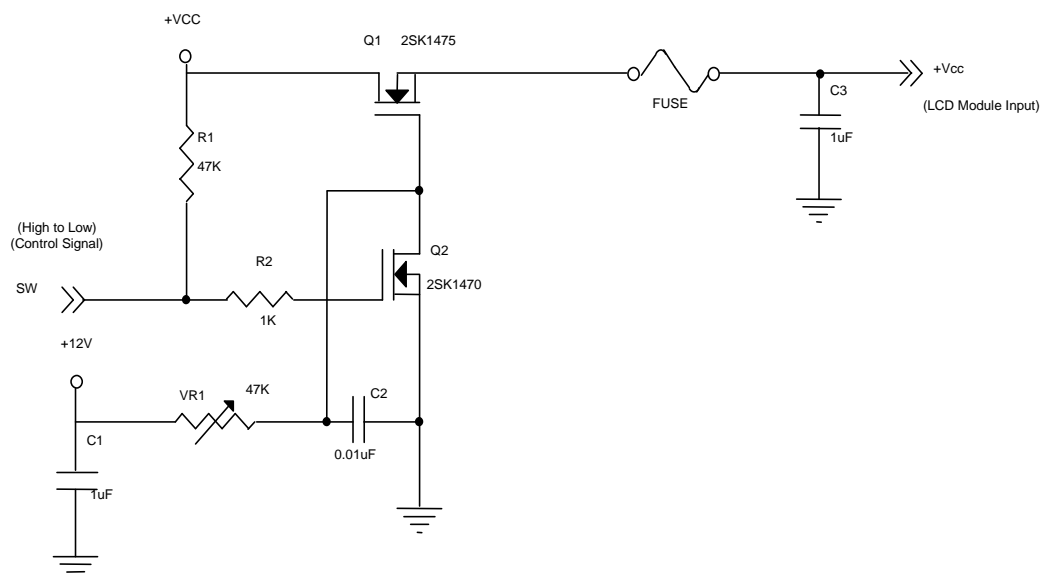

**Vcc rising time is 470μs**

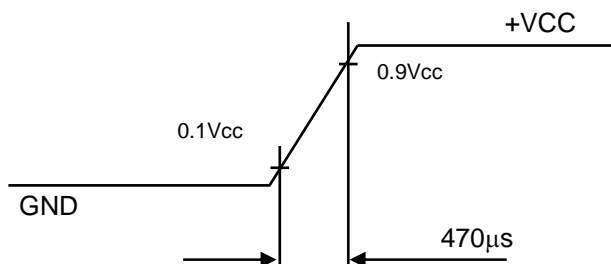



Note (3) The specified power supply current is under the conditions at  $V_{cc} = 3.3V$  or  $5V$ ,  $T_a = 25 \pm 2 \text{ }^\circ\text{C}$ ,  $f_v = 60 \text{ Hz}$ , whereas a power dissipation check pattern below is displayed.

a. White Pattern



Active Area

b. Black Pattern

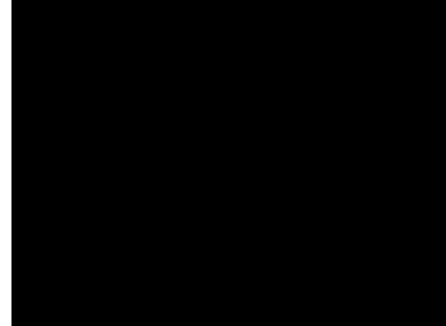

Active Area

3.2 BACKLIGHT UNIT

$T_a = 25 \pm 2 \text{ }^\circ\text{C}$

Parameter	Symbol	Value			Unit	Note	
		Min.	Typ.	Max.			
Converter Power Supply Voltage	$V_i$	7	12.0	17	V		
Converter Power Supply Current	$I_i$	-	0.4	0.5	A	@ $V_i = 12V$ (Duty 100%)	
LED Power Consumption	$P_{LED}$	-	4.8	6	W	@ $V_i = 12V$ (Duty 100%)	
EN Control Level	Backlight on	-	2.0	3.3	5.0	V	
	Backlight off	-	0	---	0.8	V	
PWM Control Level	PWM High Level	-	2.0	3.3	5.0	V	
	PWM Low Level	-	0	-	0.15	V	
PWM Control Duty Ratio	-	10	-	100	%		
PWM Control Frequency	$f_{PWM}$	190	200	210	Hz		
LED Life Time	$L_L$	30,000	-	-	Hrs	(2)	

Note (1) LED current is measured by utilizing a high frequency current meter as shown below:

Note (2) The lifetime of LED is defined as the time when it continues to operate under the conditions at  $T_a = 25 \pm 2 \text{ }^\circ\text{C}$  and Duty 100% until the brightness becomes  $\leq 50\%$  of its original value. Operating LED at high temperature condition will reduce life time and lead to color shift.

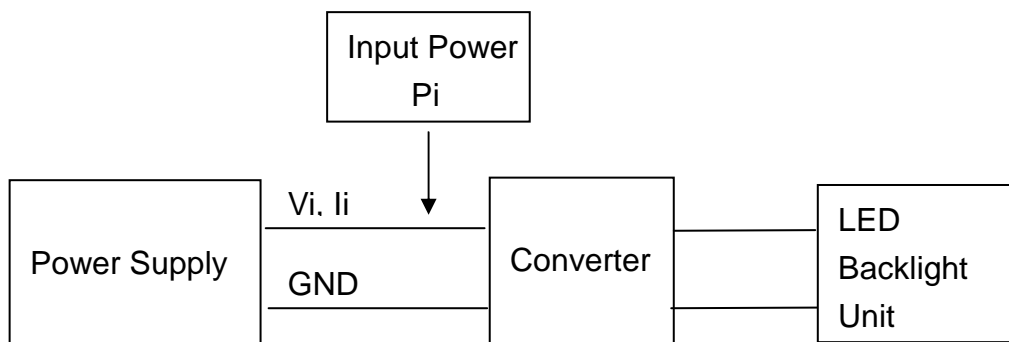

4. BLOCK DIAGRAM

4.1 TFT LCD MODULE

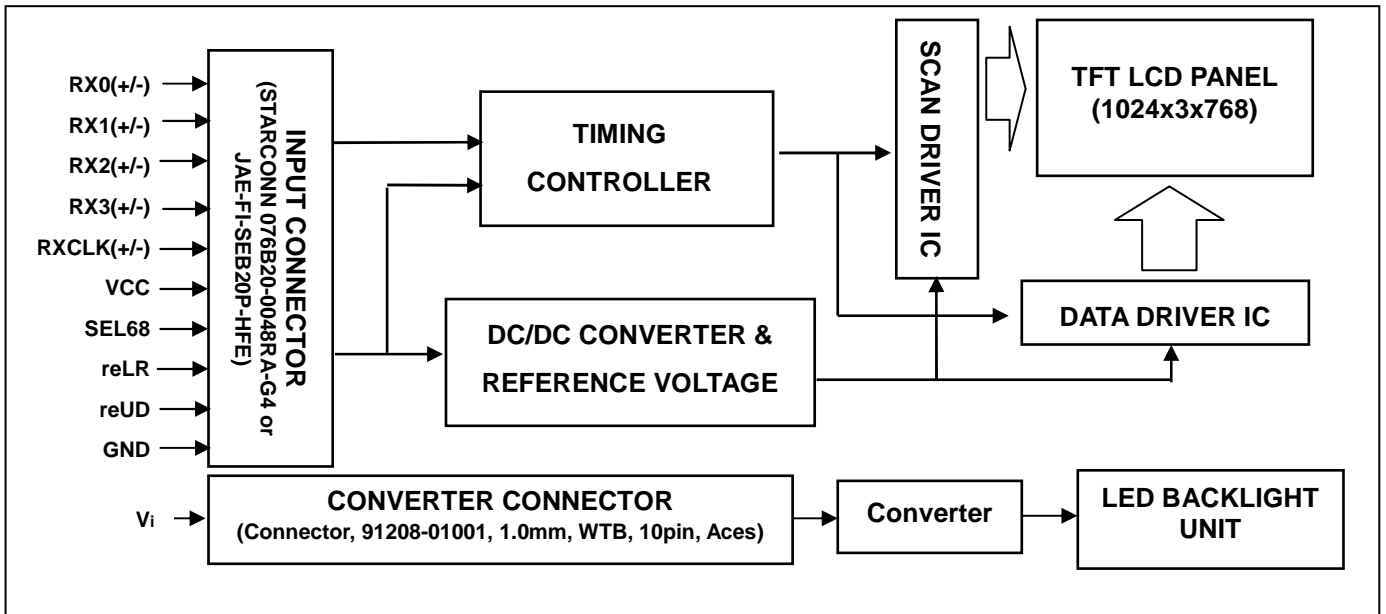

## 5. INPUT TERMINAL PIN ASSIGNMENT

### 5.1 TFT LCD MODULE

Pin	Name	Description	Remark
1	RX3+	Differential Data Input, CH3 ( Positive )	
2	RX3-	Differential Data Input, CH3 (Negative )	
3	NC	NC	
4	SEL68	LVDS 6/8 bit select function control, Low or NC → 6 bit Input Mode High → 8bit Input Mode	Note (3)
5	GND	Ground	
6	RXC+	Differential Clock Input ( Positive )	
7	RXC-	Differential Clock Input ( Negative )	
8	GND	Ground	
9	RX2+	Differential Data Input , CH2 ( Positive )	
10	RX2-	Differential Data Input , CH2 ( Negative )	
11	GND	Ground	
12	RX1+	Differential Data Input , CH1 ( Positive )	
13	RX1-	Differential Data Input, CH1 ( Negative )	
14	GND	Ground	
15	RX0+	Differential Data Input, CH0 ( Positive )	
16	RX0-	Differential Data Input, CH0 (Negative )	
17	reLR	Horizontal Reverse Scan Control, Low or NC → Normal Mode. High → Horizontal Reverse Scan	Note (3)
18	reUD	Vertical Reverse Scan Control, Low or NC → Normal Mode, High → Vertical Reverse Scan	Note (3)
19	VCC	Power supply	
20	VCC	Power supply	

Note (1) Connector Part No.: STARCONN 076B20-0048RA-G4 or JAE FI-SEB20P-HFE or equivalent.

Note (2) User's connector Part No.: JAE FI-SE20ME or equivalent.

Note (3) "Low" stands for 0V. "High" stands for 3.3V. "NC" stands for "No Connected".

### 5.2 BACKLIGHT UNIT(Converter connector pin)

Pin	Symbol	Description	Remark
1	$V_i$	Converter input voltage	12V
2	$V_i$	Converter input voltage	12V
3	$V_i$	Converter input voltage	12V
4	$V_i$	Converter input voltage	12V
5	$V_{GND}$	Converter ground	Ground
6	$V_{GND}$	Converter ground	Ground
7	$V_{GND}$	Converter ground	Ground
8	$V_{GND}$	Converter ground	Ground
9	EN	Enable pin	3.3V
10	ADJ	Backlight Adjust	PWM Dimming (190-210Hz, Hi: 3.3V <sub>DC</sub> , Lo: 0V <sub>DC</sub> )

Note (1) Connector Part No.: 91208-01001-H01 (ACES) or equivalent.

Note (2) User's connector Part No.: 91209-01011 (ACES) or equivalent

## 5.3 COLOR DATA INPUT ASSIGNMENT

The brightness of each primary color (red, green and blue) is based on the 6-bit gray scale data input for the color. The higher the binary input, the brighter the color. The table below provides the assignment of color versus data input.

Color		Data Signal																	
		Red						Green						Blue					
		R5	R4	R3	R2	R1	R0	G5	G4	G3	G2	G1	G0	B5	B4	B3	B2	B1	B0
Basic Colors	Black	0	0	0	0	0	0	0	0	0	0	0	0	0	0	0	0	0	0
	Red	1	1	1	1	1	1	0	0	0	0	0	0	0	0	0	0	0	0
	Green	0	0	0	0	0	0	1	1	1	1	1	1	0	0	0	0	0	0
	Blue	0	0	0	0	0	0	0	0	0	0	0	0	1	1	1	1	1	1
	Cyan	0	0	0	0	0	0	1	1	1	1	1	1	1	1	1	1	1	1
	Magenta	1	1	1	1	1	1	0	0	0	0	0	0	1	1	1	1	1	1
	Yellow	1	1	1	1	1	1	1	1	1	1	1	1	0	0	0	0	0	0
	White	1	1	1	1	1	1	1	1	1	1	1	1	1	1	1	1	1	1
Gray Scale Of Red	Red(0)/Dark	0	0	0	0	0	0	0	0	0	0	0	0	0	0	0	0	0	0
	Red(1)	0	0	0	0	0	1	0	0	0	0	0	0	0	0	0	0	0	0
	Red(2)	0	0	0	0	1	0	0	0	0	0	0	0	0	0	0	0	0	0
	:	:	:	:	:	:	:	:	:	:	:	:	:	:	:	:	:	:	:
	:	:	:	:	:	:	:	:	:	:	:	:	:	:	:	:	:	:	:
	:	:	:	:	:	:	:	:	:	:	:	:	:	:	:	:	:	:	:
	Red(61)	1	1	1	1	0	1	0	0	0	0	0	0	0	0	0	0	0	0
	Red(62)	1	1	1	1	1	0	0	0	0	0	0	0	0	0	0	0	0	0
Red(63)	1	1	1	1	1	1	0	0	0	0	0	0	0	0	0	0	0	0	
Gray Scale Of Green	Green(0)/Dark	0	0	0	0	0	0	0	0	0	0	0	0	0	0	0	0	0	0
	Green(1)	0	0	0	0	0	0	0	0	0	0	0	1	0	0	0	0	0	0
	Green(2)	0	0	0	0	0	0	0	0	0	0	1	0	0	0	0	0	0	0
	:	:	:	:	:	:	:	:	:	:	:	:	:	:	:	:	:	:	:
	:	:	:	:	:	:	:	:	:	:	:	:	:	:	:	:	:	:	:
	:	:	:	:	:	:	:	:	:	:	:	:	:	:	:	:	:	:	:
	Green(61)	0	0	0	0	0	0	1	1	1	1	0	1	0	0	0	0	0	0
	Green(62)	0	0	0	0	0	0	1	1	1	1	1	0	0	0	0	0	0	0
Green(63)	0	0	0	0	0	0	1	1	1	1	1	1	0	0	0	0	0	0	
Gray Scale Of Blue	Blue(0)/Dark	0	0	0	0	0	0	0	0	0	0	0	0	0	0	0	0	0	0
	Blue(1)	0	0	0	0	0	0	0	0	0	0	0	0	0	0	0	0	0	1
	Blue(2)	0	0	0	0	0	0	0	0	0	0	0	0	0	0	0	0	1	0
	:	:	:	:	:	:	:	:	:	:	:	:	:	:	:	:	:	:	:
	:	:	:	:	:	:	:	:	:	:	:	:	:	:	:	:	:	:	:
	:	:	:	:	:	:	:	:	:	:	:	:	:	:	:	:	:	:	:
	Blue(61)	0	0	0	0	0	0	0	0	0	0	0	0	1	1	1	1	0	1
	Blue(62)	0	0	0	0	0	0	0	0	0	0	0	0	1	1	1	1	1	0
Blue(63)	0	0	0	0	0	0	0	0	0	0	0	0	1	1	1	1	1	1	

Note (1) 0: Low Level Voltage, 1: High Level Voltage

The brightness of each primary color (red, green and blue) is based on the 8-bit gray scale data input for the color. The higher the binary input, the brighter the color. The table below provides the assignment of color versus data input.

Color		Data Signal																						
		Red								Green								Blue						
		R7	R6	R5	R4	R3	R2	R1	R0	G7	G6	G5	G4	G3	G2	G1	G0	B7	B6	B5	B4	B3	B2	B1
Basic Colors	Black	0	0	0	0	0	0	0	0	0	0	0	0	0	0	0	0	0	0	0	0	0	0	0
	Red	1	1	1	1	1	1	1	1	0	0	0	0	0	0	0	0	0	0	0	0	0	0	0
	Green	0	0	0	0	0	0	0	0	1	1	1	1	1	1	1	1	0	0	0	0	0	0	0
	Blue	0	0	0	0	0	0	0	0	0	0	0	0	0	0	0	0	1	1	1	1	1	1	1
	Cyan	0	0	0	0	0	0	0	0	1	1	1	1	1	1	1	1	1	1	1	1	1	1	1
	Magenta	1	1	1	1	1	1	1	1	0	0	0	0	0	0	0	0	1	1	1	1	1	1	1
	Yellow	1	1	1	1	1	1	1	1	1	1	1	1	1	1	1	1	0	0	0	0	0	0	0
	White	1	1	1	1	1	1	1	1	1	1	1	1	1	1	1	1	1	1	1	1	1	1	1
Gray Scale Of Red	Red(0) / Dark	0	0	0	0	0	0	0	0	0	0	0	0	0	0	0	0	0	0	0	0	0	0	
	Red(1)	0	0	0	0	0	0	0	1	0	0	0	0	0	0	0	0	0	0	0	0	0	0	
	Red(2)	0	0	0	0	0	0	1	0	0	0	0	0	0	0	0	0	0	0	0	0	0	0	
	:	:	:	:	:	:	:	:	:	:	:	:	:	:	:	:	:	:	:	:	:	:	:	
	:	:	:	:	:	:	:	:	:	:	:	:	:	:	:	:	:	:	:	:	:	:	:	
	Red(253)	1	1	1	1	1	1	0	1	0	0	0	0	0	0	0	0	0	0	0	0	0	0	
	Red(254)	1	1	1	1	1	1	1	0	0	0	0	0	0	0	0	0	0	0	0	0	0	0	
	Red(255)	1	1	1	1	1	1	1	1	0	0	0	0	0	0	0	0	0	0	0	0	0	0	
Gray Scale Of Green	Green(0)/ Dark	0	0	0	0	0	0	0	0	0	0	0	0	0	0	0	0	0	0	0	0	0	0	
	Green(1)	0	0	0	0	0	0	0	0	0	0	0	0	0	0	1	0	0	0	0	0	0	0	
	Green(2)	0	0	0	0	0	0	0	0	0	0	0	0	0	1	0	0	0	0	0	0	0	0	
	:	:	:	:	:	:	:	:	:	:	:	:	:	:	:	:	:	:	:	:	:	:	:	
	:	:	:	:	:	:	:	:	:	:	:	:	:	:	:	:	:	:	:	:	:	:	:	
	Green(253)	0	0	0	0	0	0	0	0	1	1	1	1	1	1	0	1	0	0	0	0	0	0	
	Green(254)	0	0	0	0	0	0	0	0	1	1	1	1	1	1	1	0	0	0	0	0	0	0	
	Green(255)	0	0	0	0	0	0	0	0	1	1	1	1	1	1	1	1	0	0	0	0	0	0	
Gray Scale Of Blue	Blue(0) / Dark	0	0	0	0	0	0	0	0	0	0	0	0	0	0	0	0	0	0	0	0	0	0	
	Blue(1)	0	0	0	0	0	0	0	0	0	0	0	0	0	0	0	0	0	0	0	0	0	1	
	Blue(2)	0	0	0	0	0	0	0	0	0	0	0	0	0	0	0	0	0	0	0	0	0	1	
	:	:	:	:	:	:	:	:	:	:	:	:	:	:	:	:	:	:	:	:	:	:	:	
	:	:	:	:	:	:	:	:	:	:	:	:	:	:	:	:	:	:	:	:	:	:	:	
	Blue(253)	0	0	0	0	0	0	0	0	0	0	0	0	0	0	0	1	1	1	1	1	1	0	
	Blue(254)	0	0	0	0	0	0	0	0	0	0	0	0	0	0	0	1	1	1	1	1	1	1	
	Blue(255)	0	0	0	0	0	0	0	0	0	0	0	0	0	0	0	1	1	1	1	1	1	1	

Note (1) 0: Low Level Voltage, 1: High Level Voltage

6. INTERFACE TIMING

6.1 INPUT SIGNAL TIMING SPECIFICATIONS

The input signal timing specifications are shown as the following table and timing diagram.

Signal	Item	Symbol	Min.	Typ.	Max.	Unit	Note
DCLK	Frequency	Fc	57.5	64.9	74.4	MHz	
Vertical Active Display Term	Total	Tv	774	806	848	Th	Tv=Tvd+Tvb
	Display	Tvd	-	768	-	Th	-
	Blank	Tvb	6	38	80	Th	-
Horizontal Active Display Term	Total	Th	1240	1344	1464	Tc	Th=Thd+Thb
	Display	Thd	-	1024	-	Tc	-
	Blank	Thb	216	320	440	Tc	-

Note (1) Since this assembly is operated in DE only mode, Hsync and Vsync input signals should be set to low logic level. Otherwise, this assembly would operate abnormally.

(2) Frame rate is 60Hz

**INPUT SIGNAL TIMING DIAGRAM**

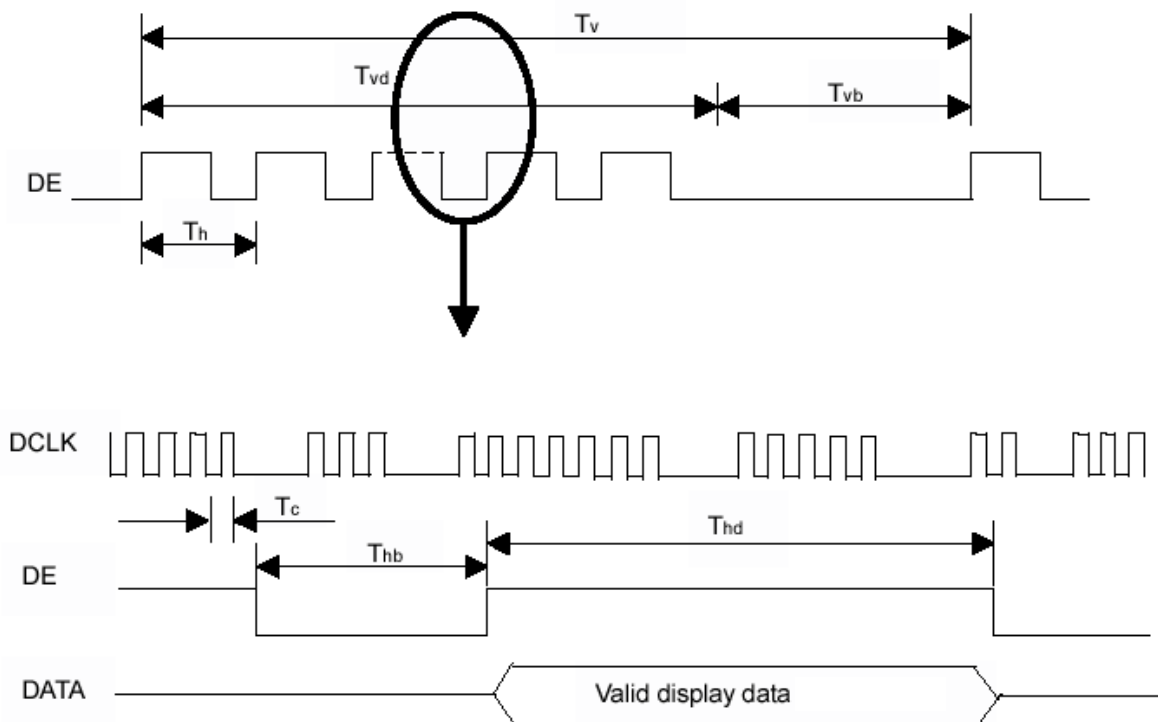

6.2 POWER ON/OFF SEQUENCE

To prevent a latch-up or DC operation of LCD assembly, the power on/off sequence should be as the diagram below.

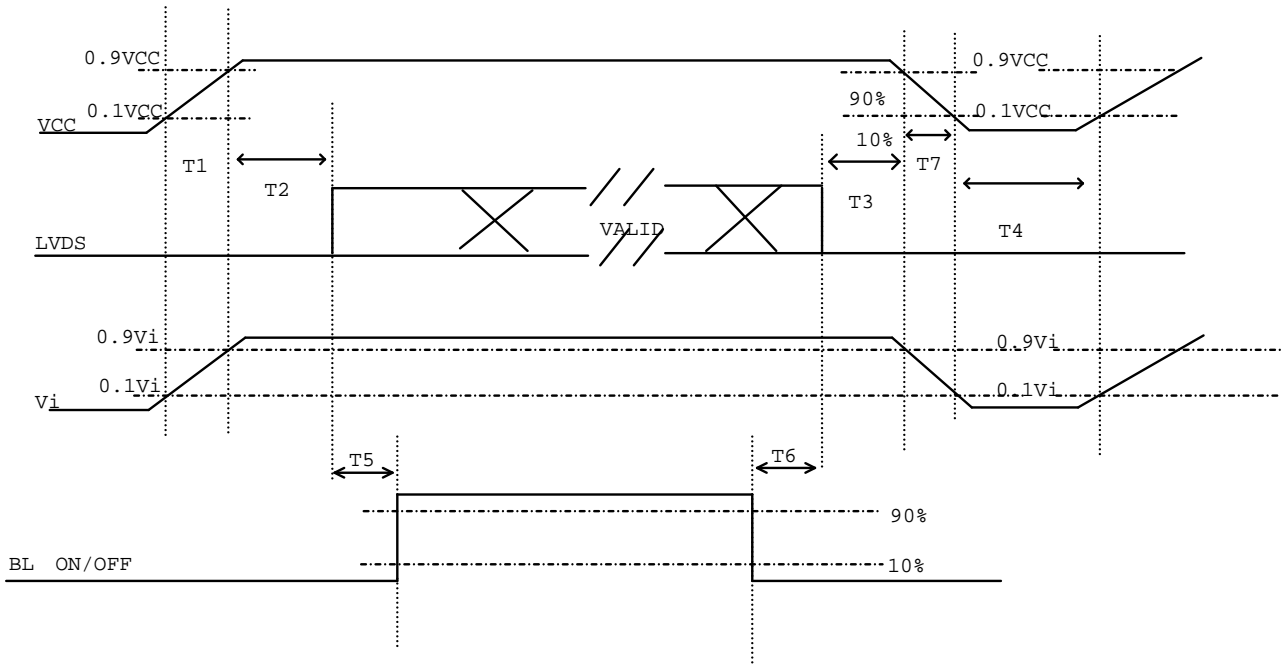

**Power ON/OFF sequence**

Note (1) Please avoid floating state of interface signal at invalid period.

Note (2) When the interface signal is invalid, be sure to pull down the power supply of LCD VCC to 0 V.

Note (3) The Backlight converter power must be turned on after the power supply for the logic and the interface signal is valid. The Backlight converter power must be turned off before the power supply for the logic and the interface signal is invalid.

Parameter	Value			Units
	Min	Typ	Max	
T1	0.5	-	10	ms
T2	0	-	50	ms
T3	0	-	50	ms
T4	500	-	-	ms
T5	200	-	-	ms
T6	200	-	-	ms
T7	5	-	300	ms

6.3 The Input Data Format

SEL68 = "Low" or "NC" for 6 bits LVDS Input

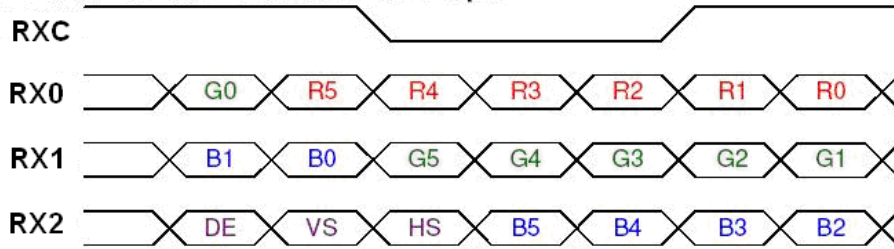

SEL68 = "High" for 8 bits LVDS Input

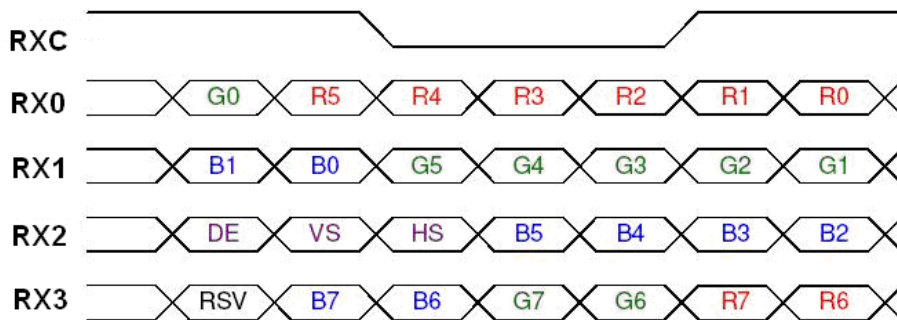

Note (1) R/G/B data 7: MSB, R/G/B data 0: LSB

Note (2) Please follow PSWG

Signal Name	Description	Remark
R7	Red Data 7 (MSB)	Red-pixel Data Each red pixel's brightness data consists of these 8 bits pixel data.
R6	Red Data 6	
R5	Red Data 5	
R4	Red Data 4	
R3	Red Data 3	
R2	Red Data 2	
R1	Red Data 1	
R0	Red Data 0 (LSB)	
G7	Green Data 7 (MSB)	Green-pixel Data Each green pixel's brightness data consists of these 8 bits pixel data.
G6	GreenData 6	
G5	GreenData 5	
G4	GreenData 4	
G3	GreenData 3	
G2	GreenData 2	
G1	GreenData 1	
G0	GreenData 0 (LSB)	
B7	Blue Data 7 (MSB)	Blue-pixel Data Each blue pixel's brightness data consists of these 8 bits pixel data.
B6	Blue Data 6	
B5	Blue Data 5	
B4	Blue Data 4	
B3	Blue Data 3	
B2	Blue Data 2	
B1	Blue Data 1	
B0	Blue Data 0 (LSB)	
RXCLKIN+ RXCLKIN-	LVDS Clock Input	
DE	Display Enable	
VS	Vertical Sync	
HS	Horizontal Sync	

Note (3) Output signals from any system shall be low or Hi-Z state when VCC is off.



6.4 Scanning Direction

The following figures show the image see from the front view. The arrow indicates the direction of scan.

**Fig.1 Normal Scan**



**Fig.2 Reverse Scan**



**Fig.3 Reverse Scan**



**Fig.4 Reverse Scan**



Fig. 1 Normal scan ( pin 17, reLR = Low or NC, pin 18, reUD = Low or NC )

Fig. 2 Reverse scan ( pin 17, reLR = High, pin 18, reUD = Low or NC )

Fig. 3 Reverse scan ( pin 17, reLR = Low or NC, pin 18, reUD = High )

Fig. 4 Reverse scan ( pin 17, reLR = High, pin 18, reUD = High )

## 7. OPTICAL CHARACTERISTICS

### 7.1 TEST CONDITIONS

Item	Symbol	Value	Unit
Ambient Temperature	Ta	25±2	°C
Ambient Humidity	Ha	50±10	%RH
Supply Voltage	V <sub>CC</sub>	3.3	V
Input Signal	According to typical value in "3. ELECTRICAL CHARACTERISTICS"		
Converter Voltage	V <sub>in</sub>	12	V
Converter Duty		100%	

### 7.2 OPTICAL SPECIFICATIONS

The relative measurement methods of optical characteristics are shown in 7.2. The following items should be measured under the test conditions described in 7.1 and stable environment shown in Note (5).

Item	Symbol	Condition	Min.	Typ.	Max.	Unit	Note				
Color Chromaticity	Red	$\theta_x=0^\circ, \theta_y=0^\circ$ CS-1000	Typ - 0.05	0.625	Typ + 0.05	-	(1), (5)				
				0.358		-					
	Green			0.324		-					
				0.604		-					
	Blue			0.144		-					
				0.088		-					
	White			0.313		-					
				0.329		-					
	Center Luminance of White			L <sub>C</sub>		400		500	-	-	(4), (5)
	Contrast Ratio			CR		500		700	-	-	(2), (5)
Response Time	T <sub>R</sub>	$\theta_x=0^\circ, \theta_y=0^\circ$	-	5	10	ms	(3)				
	T <sub>F</sub>		-	11	16	ms					
White Variation	$\delta W$	$\theta_x=0^\circ, \theta_y=0^\circ$	-	1.25	1.4	-	(5), (6)				
Viewing Angle	Horizontal	CR≥10	70	80	-	Deg.	(1), (5)				
			70	80	-						
	Vertical		60	70	-						
			60	70	-						

Note (1) Definition of Viewing Angle ( $\theta_x, \theta_y$ ):

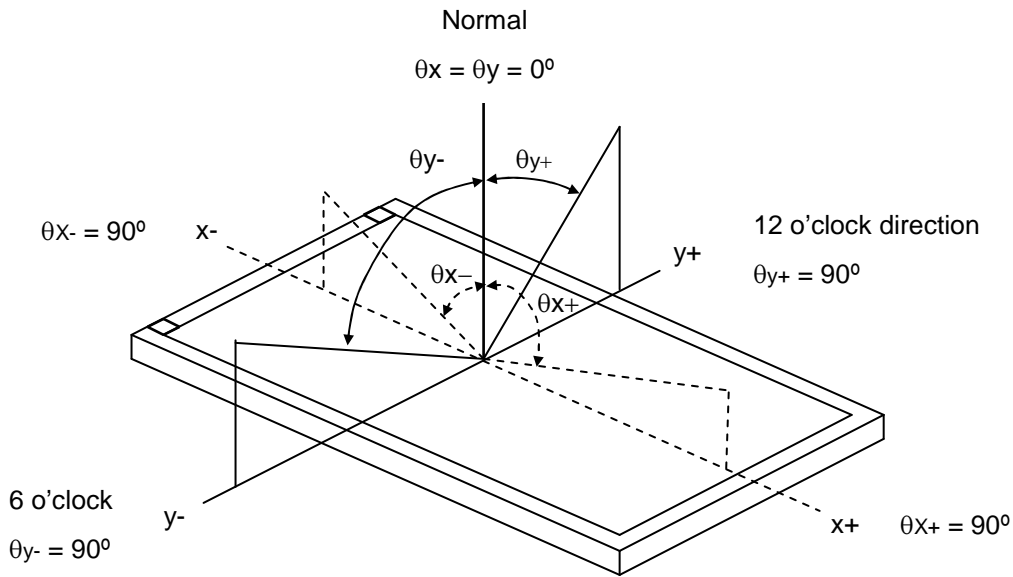

Note (2) Definition of Contrast Ratio (CR):

The contrast ratio can be calculated by the following expression.

$$\text{Contrast Ratio (CR)} = L_{63} / L_0$$

L63: Luminance of gray level 63

L 0: Luminance of gray level 0

$$\text{CR} = \text{CR} (5)$$

CR (X) is corresponding to the Contrast Ratio of the point X at Figure in Note (6).

Note (3) Definition of Response Time ( $T_R, T_F$ ) and measurement method:

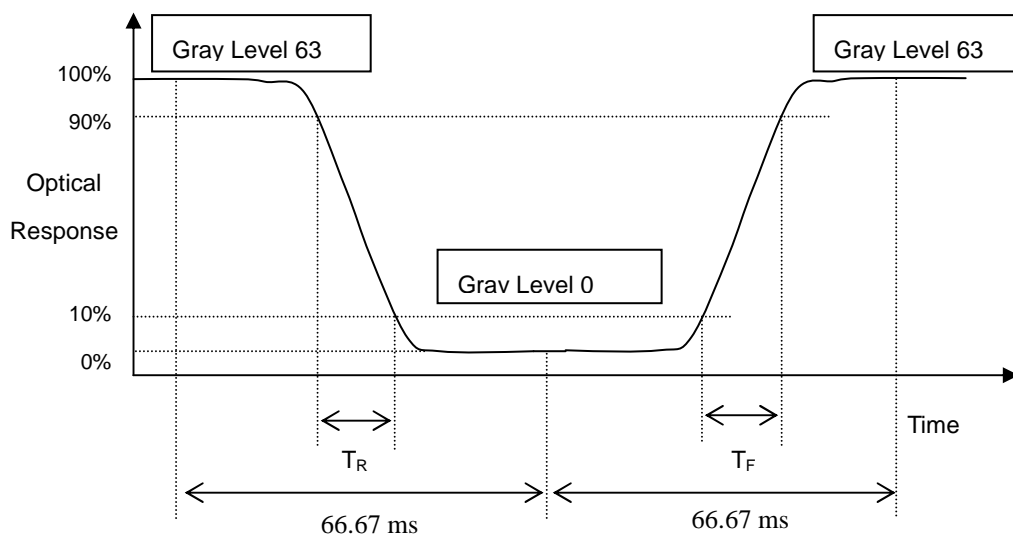

Note (4) Definition of Luminance of White ( $L_C$ ):

Measure the luminance of gray level 63 at center point

$$L_C = L(5)$$

$L(x)$  is corresponding to the luminance of the point X at Figure in Note (6).

Note (5) Measurement Setup:

The LCD module should be stabilized at given temperature for 20 minutes to avoid abrupt temperature change during measuring. In order to stabilize the luminance, the measurement should be executed after lighting Backlight for 20 minutes in a windless room.

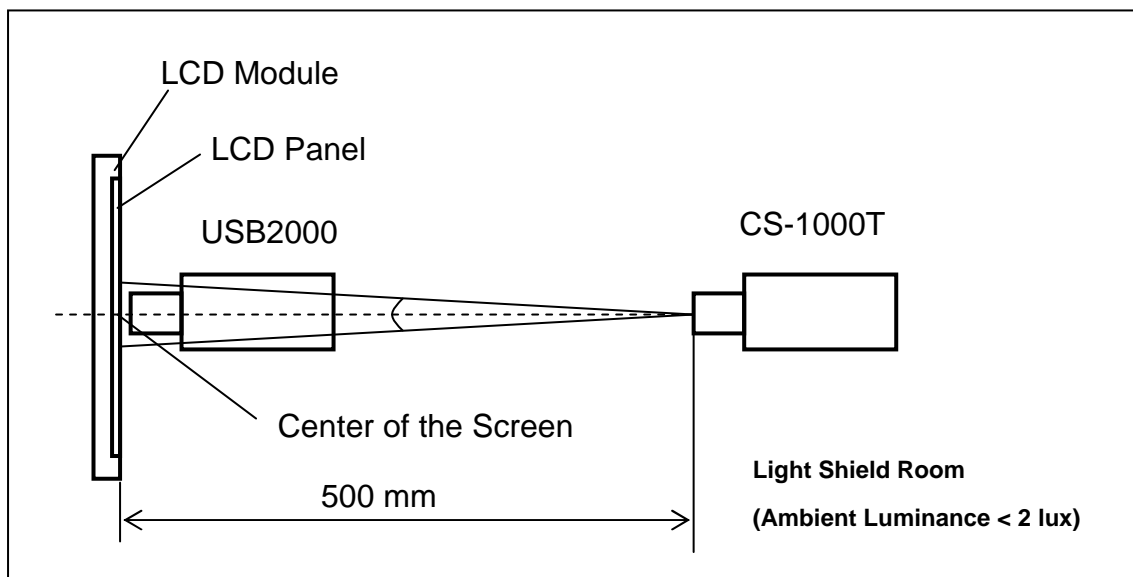

Note (6) Definition of White Variation ( $\delta W$ ):

Measure the luminance of gray level 63 at 5 points

$$\delta W = \frac{\text{Maximum [L (1), L (2), L (3), L (4), L (5)]}}{\text{Minimum [L (1), L (2), L (3), L (4), L (5)]}}$$

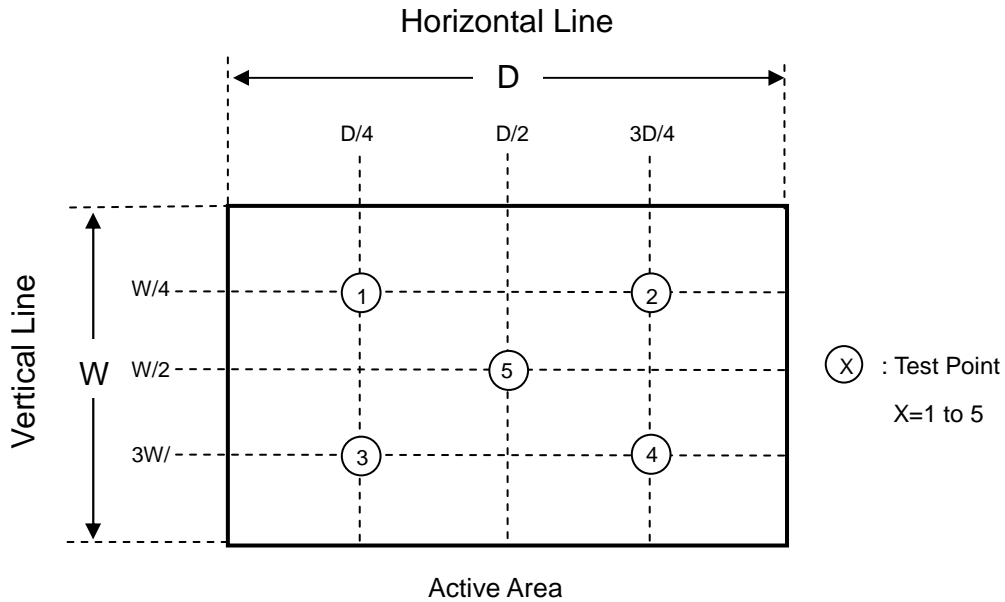

## 8. RELIABILITY TEST CRITERIA

Test Item	Test Condition	Note
High Temperature Storage Test	80°C, 240 hours	(1)(2)(4) (5)
Low Temperature Storage Test	-40°C, 240 hours	
Thermal Shock Storage Test	-30°C, 0.5hour $\longleftrightarrow$ 70°C, 0.5hour; 1hour/cycle,100cycles	
High Temperature Operation Test	70°C, 240 hours	
Low Temperature Operation Test	-30°C, 240 hours	
High Temperature & High Humidity Operation Test	60°C, 90%RH, 240hours	(1)(2)(4) (6)
Shock (Non-Operating)	200G, 2ms, half sine wave, 1 time for $\pm X$ , $\pm Y$ , $\pm Z$ .	(3)(4)
Vibration (Non-Operating)	1.5G, 10 ~ 300 Hz, 10min/cycle, 3 cycles each X, Y, Z	(3)(4)

Note (1) There should be no condensation on the surface of panel during test.

Note (2) Temperature of panel display surface area should be 80 °C Max.

Note (3) At testing Vibration and Shock, the fixture in holding the module has to be hard and rigid enough so that the module would not be twisted or bent by the fixture.

Note (4) In the standard conditions, there is no function failure issue occurred. All the cosmetic specifications are judged before reliability test.

Note (5) Before cosmetic and function test, the product must have enough recovery time, at least 2 hours at room temperature.

Note (6) Before cosmetic and function test, the product must have enough recovery time, at least 24 hours at room temperature.

9. PACKAGING

9.1 PACKING SPECIFICATIONS

- (1) 16pcs LCD modules / 1 Box
- (2) Box dimensions: 465 (L) X 362 (W) X 314 (H) mm
- (3) Weight: approximately 9.13Kg (16 modules per box)

9.2 PACKING METHOD

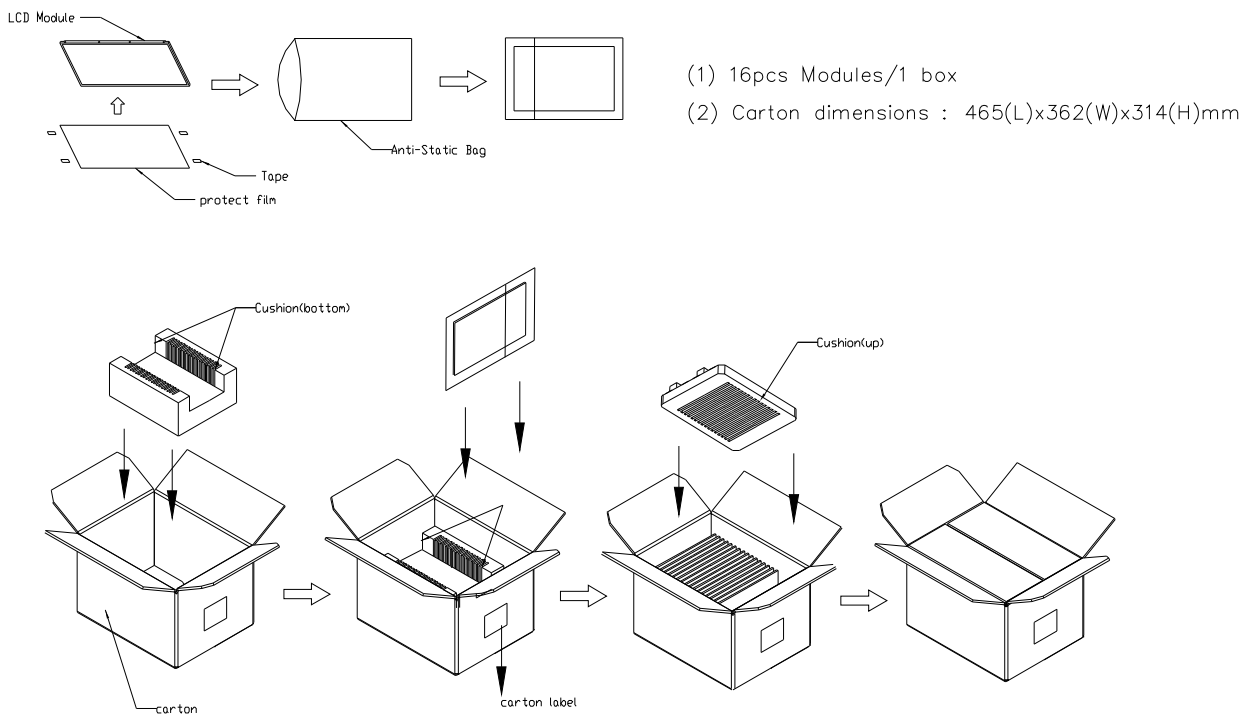
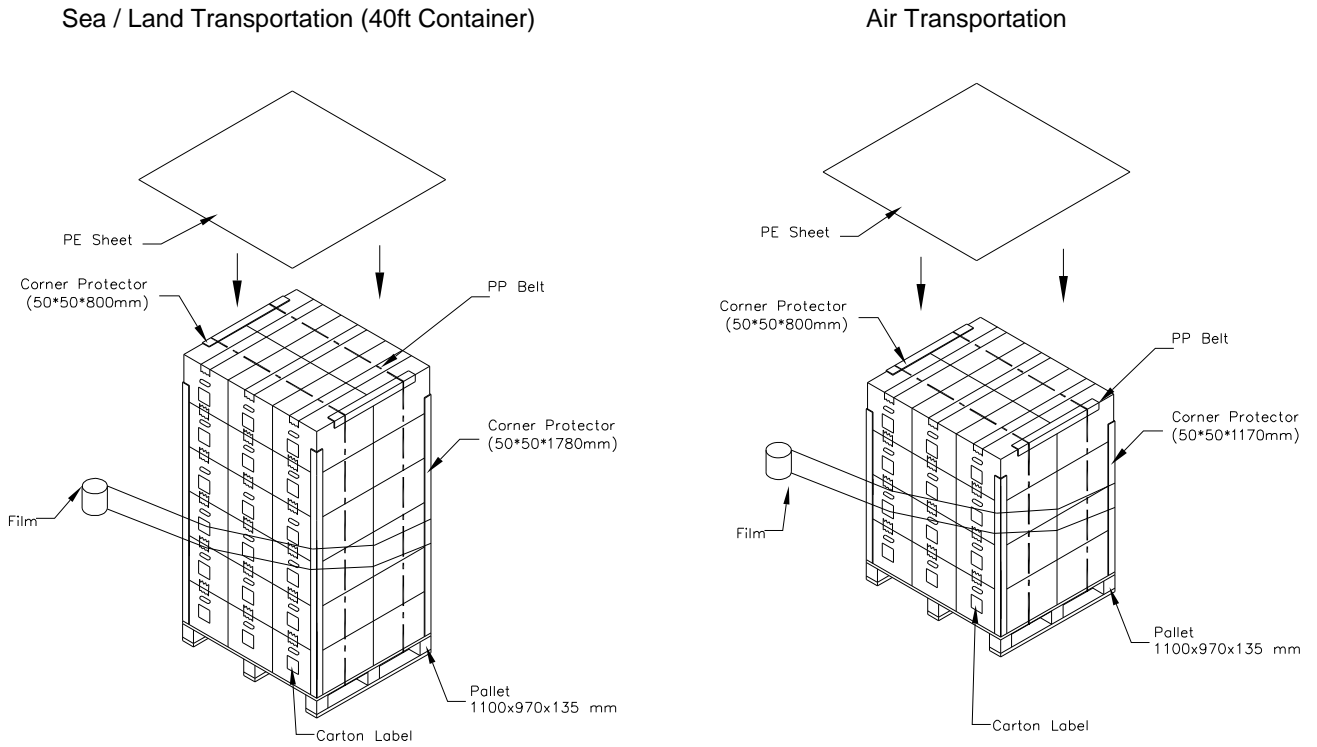

Figure. 9-1 Packing method



**Figure. 9-2 Packing method**



10. DEFINITION OF LABELS

10.1 INNOLUX MODULE LABEL

The barcode nameplate is pasted on each module as illustration, and its definitions are as following explanation.

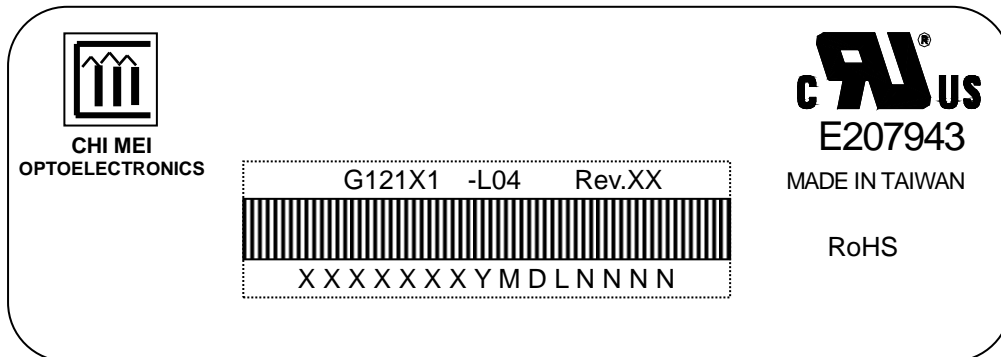

- (a) Model Name: G121X1 -L04
- (b) Revision: Rev. XX, for example: A1, ...C1, C2 ...etc.
- (c) Serial ID: X X X X X X Y M D X N N N N

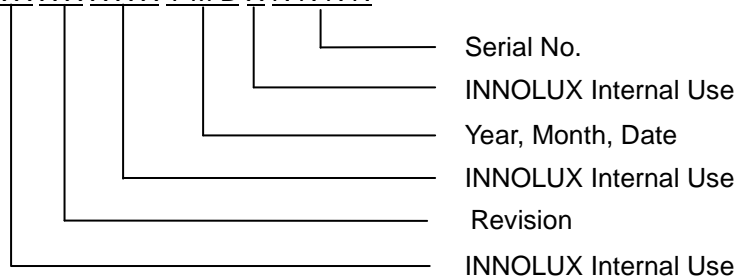

Serial ID includes the information as below:

- (a) Manufactured Date: Year: 1~9, for 2011~2019  
 Month: 1~9, A~C, for Jan. ~ Dec.  
 Day: 1~9, A~Y, for 1<sup>st</sup> to 31<sup>st</sup>, exclude I , O and U
- (b) Revision Code: cover all the change
- (c) Serial No.: Manufacturing sequence of product

## 11. PRECAUTIONS

### 11.1 ASSEMBLY AND HANDLING PRECAUTIONS

- (1) Do not apply rough force such as bending or twisting to the module during assembly.
- (2) To assemble or install module into user's system can be only in clean working areas. The dust and oil may cause electrical short or worsen the polarizer.
- (3) It's not permitted to have pressure or impulse on the module because the LCD panel and Backlight will be damaged.
- (4) Always follow the correct power sequence when LCD module is connecting and operating. This can prevent damage to the CMOS LSI chips during latch-up.
- (5) Do not pull the I/F connector in or out while the module is operating.
- (6) Do not disassemble the module.
- (7) Use a soft dry cloth without chemicals for cleaning, because the surface of polarizer is very soft and easily scratched.
- (8) It is dangerous that moisture come into or contacted the LCD module, because moisture may damage LCD module when it is operating.
- (9) High temperature or humidity may reduce the performance of module. Please store LCD module within the specified storage conditions.
- (10) When ambient temperature is lower than 10°C may reduce the display quality. For example, the response time will become slowly.
- (11) Do not keep same pattern in a long period of time. It may cause image sticking on LCD.

### 11.2 SAFETY PRECAUTIONS

- (1) Do not disassemble the module or insert anything into the Backlight unit.
- (2) If the liquid crystal material leaks from the panel, it should be kept away from the eyes or mouth. In case of contact with hands, skin or clothes, it has to be washed away thoroughly with soap.
- (3) After the module's end of life, it is not harmful in case of normal operation and storage.

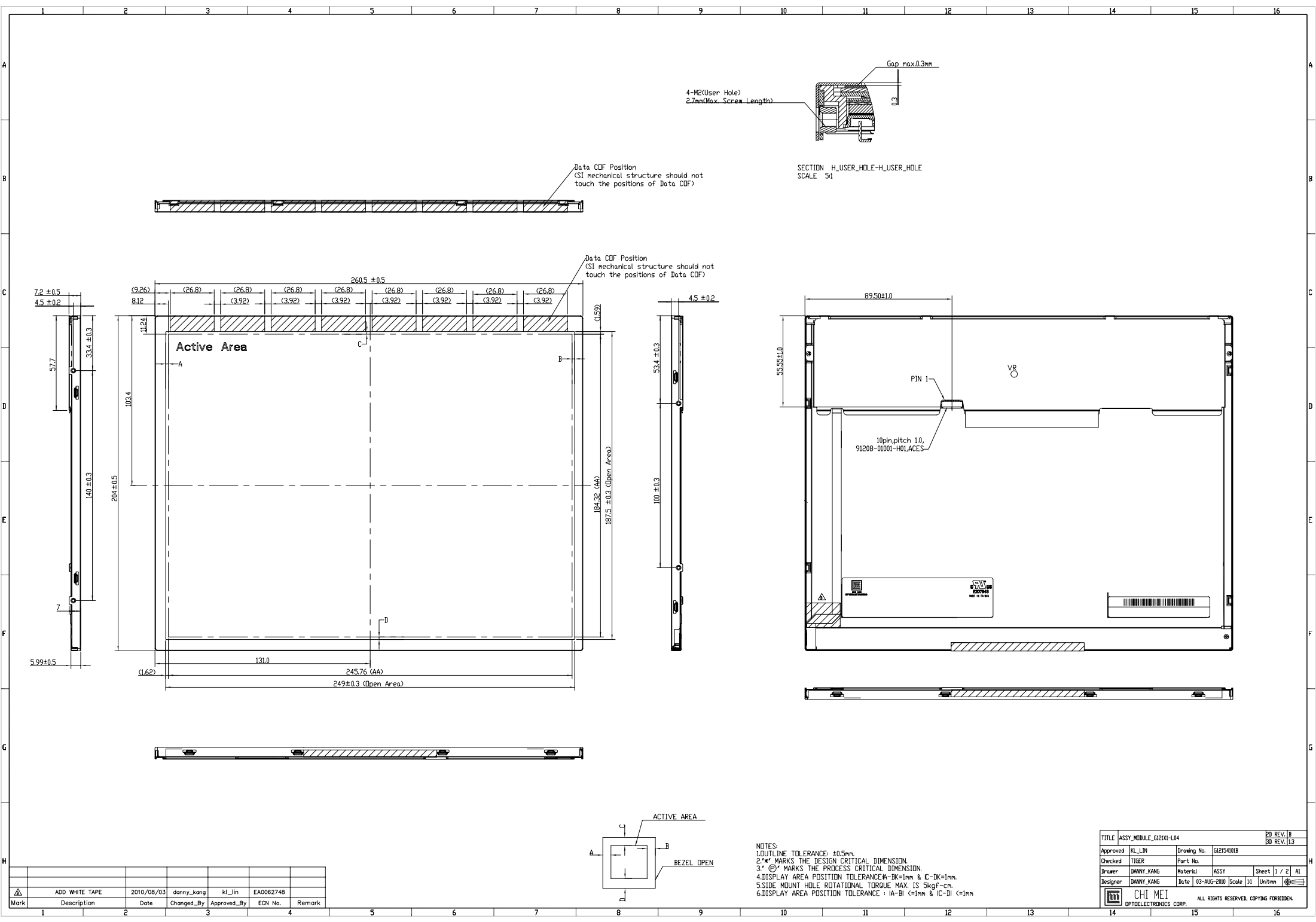

Data CDF Position  
(SI mechanical structure should not touch the positions of Data CDF)

Data CDF Position  
(SI mechanical structure should not touch the positions of Data CDF)

SECTION H\_USER\_HOLE-H\_USER\_HOLE  
SCALE 5/1

Active Area

PIN 1

10pin,pitch 1.0,  
91208-01001-H01ACES

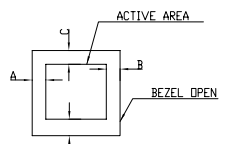

- NOTES:
- 1.OUTLINE TOLERANCE: ±0.5mm.
  - 2.\*\* MARKS THE DESIGN CRITICAL DIMENSION.
  - 3.\* @Y MARKS THE PROCESS CRITICAL DIMENSION.
  - 4.DISPLAY AREA POSITION TOLERANCE(A-BK=1mm & C-IX=1mm).
  - 5.SIDE MOUNT HOLE ROTATIONAL TDRQUE MAX. IS 5kgf-cm.
  - 6.DISPLAY AREA POSITION TOLERANCE : IA-BI <=1mm & IC-DI <=1mm

Mark	Description	Date	Changed_By	Approved_By	ECN No.	Remark
Δ	ADD WHITE TAPE	2010/08/03	danny_kang	kl_jin	EAD062748	

TITLE ASSY_MODULE_G121X1-L04				PD REV. 1B	
				BD REV. 1L3	
Approved	KL_LIN	Drawing No.	G121S4101B		
Checked	TIGER	Part No.			
Drawer	DANNY_KANG	Material	ASSY	Sheet	1 / 2
Designer	DANNY_KANG	Date	03-AUG-2010	Scale	1:1
				ALL RIGHTS RESERVED. COPYING FORBIDDEN.	